

# WIRELESS COMMUNICATION FACILITIES

Highlights and Overview

# FCC Regulations

- The FCC has classified wireless communication companies as a utility.
- Wireless communication companies may now utilize the FCC guidelines and regulations to install small cell wireless facilities (5G) in public/private way.
- Wireless communication companies may now start applying to municipal communities for the installation of wireless equipment in the public/private way.
- There is a good legal argument that the FCC order pertaining to small cell wireless facility does not apply to RMLD.
- However, RMLD is working in good faith to accommodate new technology.
- The Master Agreement does not hold a “Shot Clock” but has agreed to 60 days to respond to properly completed applications and 30 days to schedule and complete the work.

## Permitting Town and RMLD

- Each wireless company must apply to each municipality and be granted permission to install wireless facilities in the public/private right of way within that community.
- The municipality shall provide the town's aesthetic policy to each applicant.
- The wireless companies shall also enter into agreement with the RMLD through its Pole License Agreement process and the Joint Pole owner approval process.
- Once a wireless company has been granted permission by the respective town, the wireless company shall make application (up to 10 pole licenses per application) to the RMLD.

# Small Cell Signaling 3<sup>rd</sup> Party Equipment Attachment Process

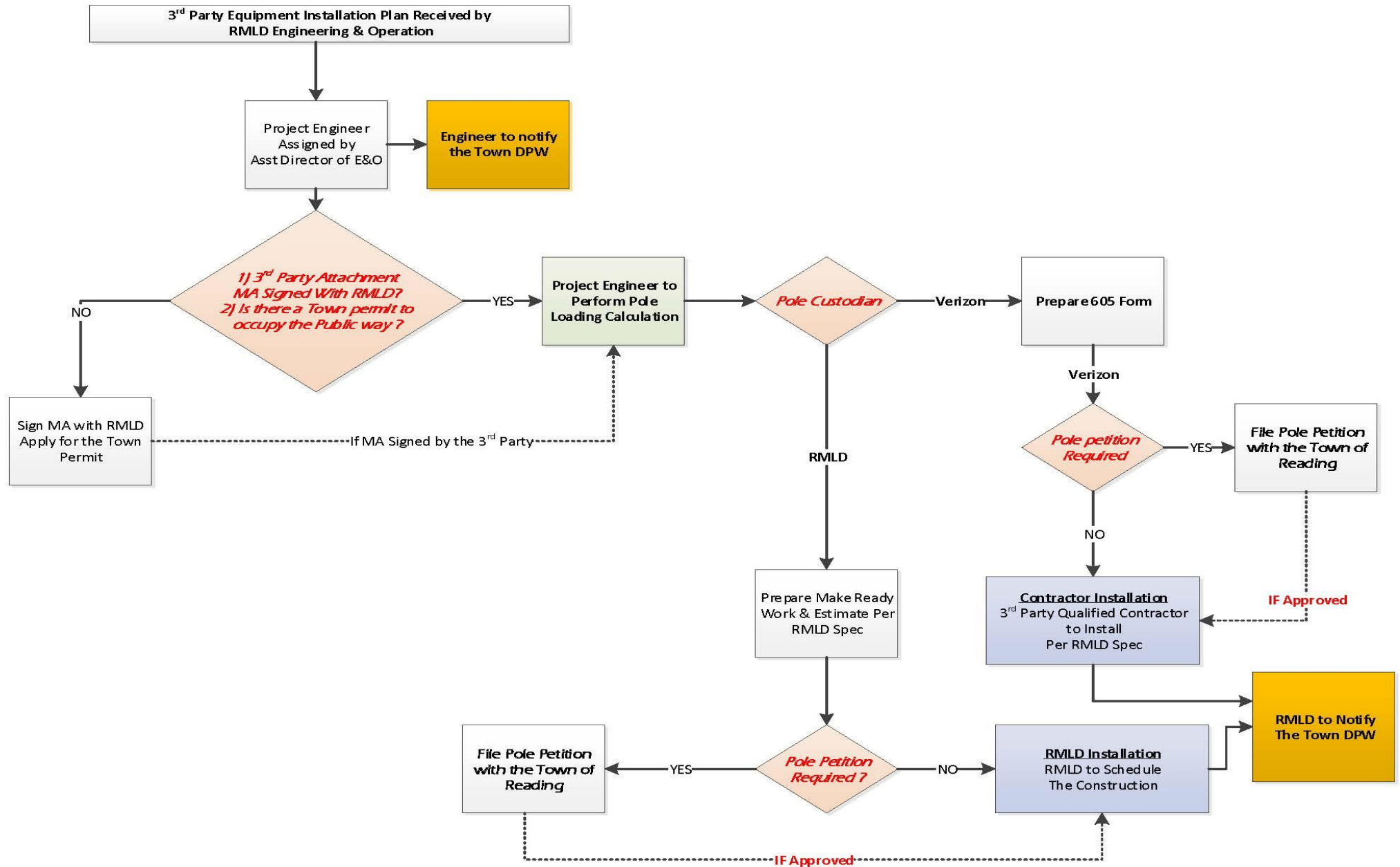

# Notifications

- The town is requested to notify RMLD when a wireless company has been granted permit to install wireless equipment in the public way.
- RMLD will notify the town, to promote communication of each application, location, and proposed wireless facility.
- RMLD will also notify the town the status of each pole license application after a full engineering review and analysis of the proposed wireless facility; approved or denied.
- A denied pole license attachment may result in the wireless company petitioning the town for a new sole owned pole to install new wireless equipment. The RMLD is not responsible to evaluate other potential structure attachments.
- RMLD may be required to install poles to provide service to new sole owned wireless communication structures.

# Aesthetics

- It is recommended that the town review RMLD's Master Agreement and technical specifications when creating/reviewing an aesthetic policy so as to align, i.e. pole height, equipment dimensions.
- RMLD will review each respective town's aesthetic policy and provide comments to ensure continued alignment.

**NOTES:**

1. CLASS OF POLE SHALL BE EVALUATED ON CASE BY CASE BASIS.
2. ANTENNA INSTALLED IN SUPPLY SPACE SHALL BE MAINTAINED BY QUALIFIED PERSONNEL.
3. COMMUNICATION CABLES SHALL BE INSTALLED IN CONDUIT ALONG POLE. CONDUIT SHALL BE ROUTED SUCH THAT CLEARANCE FROM OTHER FACILITIES ATTACHED TO POLE IS MAXIMIZED.
4. ALL DEVICES SHALL BE BONDED TO THE UTILITY POLE DOWN GROUND.
5. RMLD ENGINEERING SHALL CONFIRM MID-SPAN CONDUCTOR CLEARANCES ARE IN ACCORDANCE WITH NESC.
6. RMLD ENGINEERING WILL PERFORM AN ENGINEERING LOAD ANALYSIS ON EACH POLE TO DETERMINE APPROPRIATE POLE HEIGHT AND CLASS.
7. ALL INSTALLATIONS MUST COMPLY WITH NEC AND NFPA CODES.

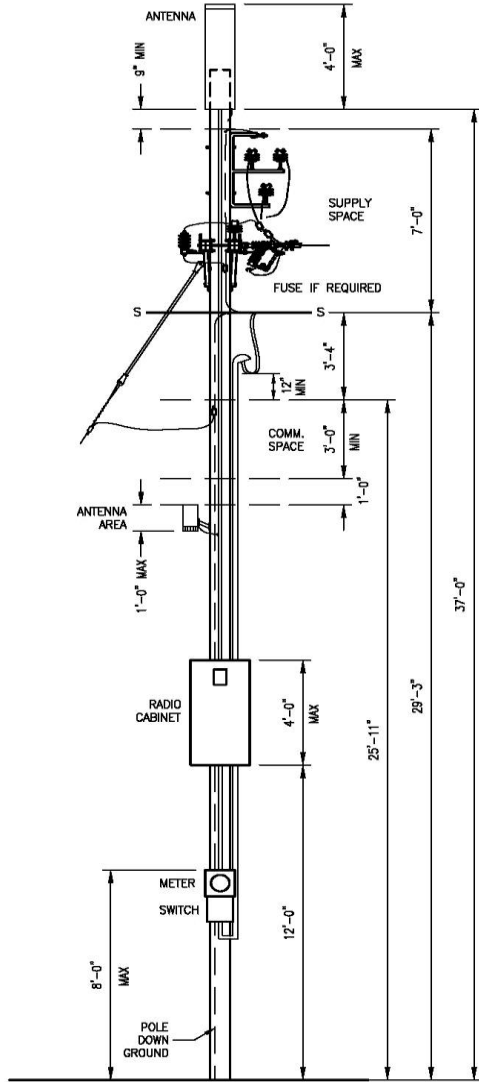

**NOTES:**

1. CLASS OF POLE SHALL BE EVALUATED ON CASE BY CASE BASIS.
2. ANTENNA INSTALLED IN SUPPLY SPACE SHALL BE MAINTAINED BY QUALIFIED PERSONNEL.
3. COMMUNICATION CABLES SHALL BE INSTALLED IN CONDUIT ALONG POLE. CONDUIT SHALL BE ROUTED SUCH THAT CLEARANCE FROM OTHER FACILITIES ATTACHED TO POLE IS MAXIMIZED.
4. ALL DEVICES SHALL BE BONDED TO THE UTILITY POLE DOWN GROUND.
5. RMLD ENGINEERING SHALL CONFIRM MID-SPAN CONDUCTOR CLEARANCES ARE IN ACCORDANCE WITH NESC.
6. RMLD ENGINEERING WILL PERFORM AN ENGINEERING LOAD ANALYSIS ON EACH POLE TO DETERMINE APPROPRIATE POLE HEIGHT AND CLASS.
7. ALL INSTALLATIONS MUST COMPLY WITH NEC AND NFPA CODES.

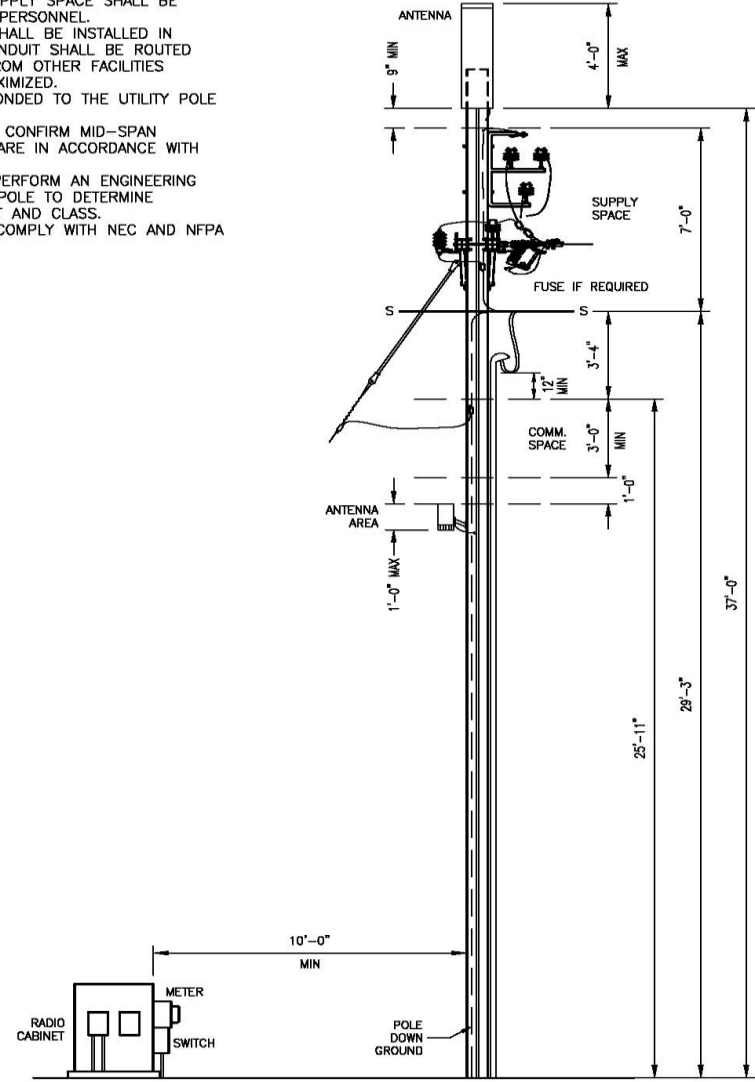

South Fern St & 25<sup>th</sup> St - 5 Party Pole (Dominion Energy)







Thank you